



ENVASES SANZ BELDA, S.L.

Tel.: 34 96 236 02 32 - calidad@envasesanzbelda.es - www.envasesanzbelda.es
Pol. Ind. San José. Avda, Valencia, parc. 7 - Apdo. de Correos 46 - 46812 Aielo de Malferit. Valencia. (España)



Technical comercial data

M.N-16-P T.E-16

Serie MASTER NOVA – Versión 24-01-2024

TECHNICAL DATA:

Material:	PP copolymer of first quality, suitable for contact with food according to current regulations.
Colours:	White standard. Consult for other colours.
Useful Volume:	16 litres
Volume to the edge:	19 litres
Weight of the bucket:	600 g. approx.
Weight of the lid:	168 g. approx
Weight of the handle (plastic):	35 g. approx.
Total Weight:	803 g. approx.
Decorative surface flat inks:	190 x 911 mm (height x perimeter)
Design surface photographic finish:	210 x 930 mm (height x perimeter)



MEASUREMENTS:

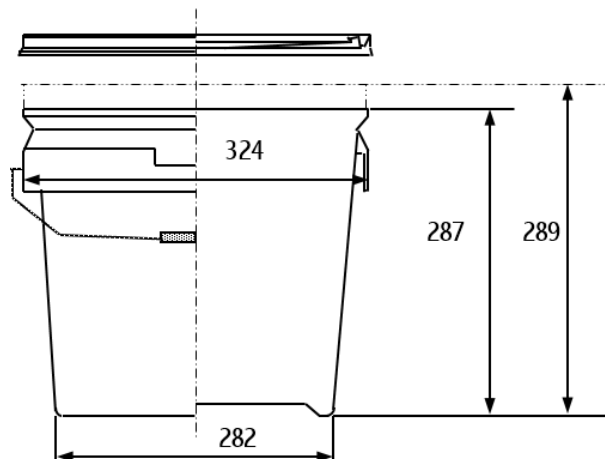

Measurements in millimetres

GROUPING OF TRANSPORT:

Buckets:	360 buckets per pallet
Pallet dimensions:	1325 x 1000 x 2250 (see drawing)
Lids:	60 lids per bag, this serves as a packaging of transportation
Bag dimension:	∅ 324 x 910

